

Manual for LT2



Contents

Product Information	6
<i>Facts</i>	6
<i>Serial number.....</i>	6
<i>Initial operation.....</i>	6
<i>Power on crank or flywheel.....</i>	6
<i>Calories.....</i>	6
Bike adjustments.....	8
<i>Adjustments of the bike.....</i>	8
<i>Bike adjustments.....</i>	8
<i>Daily check.....</i>	8
Pulse function.....	9
<i>Pulse standard (chest belts)</i>	9
<i>Pairing display and chest belt</i>	9
Display Description	10
<i>Sleep mode.....</i>	10
<i>Workload adjustment</i>	10
<i>Personal settings</i>	11
<i>Alternative power / force display.....</i>	11
User settings.....	12
<i>Units</i>	12
<i>Cycle constant</i>	12
<i>Metronome cadence</i>	12
<i>BikeID</i>	12
<i>Current potentiometer value</i>	13
Calibration.....	13
Training	14
METS	15
Troubleshooting guide.....	16
Service.....	17
<i>Warning.....</i>	17
<i>Warranty</i>	17
<i>Service check and Maintenance</i>	17
<i>Batteries.....</i>	18
<i>Flywheel bearing.....</i>	18
<i>Crank bearing</i>	18
<i>Transportation</i>	18
<i>Replacement of brake belt.....</i>	18
<i>Brake belt contact surface</i>	18
<i>Chain 1/2" x 1/8"</i>	19
<i>Freewheel sprocket.....</i>	20
Spare parts list	21

Important

Read the manual carefully before using the cycle
and save it for future use.

Monark Exercise AB

Monark has 100 years' experience of bicycle production. The Monark tradition has yielded know-how, experience, and a real feel for the product and quality. Since the early 1900s, Monark bikes have been living proof of precision, reliability, strength and service. Those are the reasons why we now are the world leader in ergometer bikes and the market leader in Scandinavia in transport bikes.

We manufacture, develop and market ergometers and exercise bikes, transport bikes and specialized bikes. Our largest customer groups are within health care, sports medicine, public authorities, industry and postal services.

For more information: <http://www.monarkexercise.se>



Thank you for choosing a test cycle from Monark!

Ideal position is important for a performance to reach its maximum and increases the potential for a perfect performance. The new setting options, along with an upgraded workload adjustment, make Monark's renowned bike even better.

- LT2 has a frame that is adjustable in all directions
- LT2's rane also means the Q-factor can be reduced, which increases the opportunities for a better workout experience
- LT2 gives the conditions; the rest is up to the rider
- LT2 is equipped with a newly-developed manual workload control, the workload is controlled by a lever located on the handlebar
- LT2 can be calibrated, both mechanically and electronically



NOTE!

Use of the product may involve considerable physical stress. It is therefore recommended that people who are not accustomed to cardiovascular exercise or who do not feel completely healthy, should consult a physician for advice.

Product Information

Facts

NOTE! Before you start using the bike - remember to remove any transport protection and protective tape on the flywheel.

Technical details

Length	1405 mm (75")
Width	640 mm (26 3/4")
Height (max at display)	1240 mm (42")
Height (max at saddle)	1240 mm (42")
Weight	57 kg
Weight flywheel	20 kg
Max user weight	180 kg
Painting	Industrial powder coating
Rust protection	Zinc-based basic powder coating on exposed areas

Power output

Continuous (50-100 rpm)	15-700 W
Peak (at rpm)	1400 W (200 rpm)
Smallest increment	1 W

Recommended accessories

- Calibration weight, 2 and 4 kg
- Chest belt
- Power adaptor

Technical data power adaptor (accessory)

Output voltage: +9 V DC

Current: 500 mA

Polarity: Minus (-) in the middle of connector. See *Fig: Polarity*.

(Art. No. 9384-650, USA Art. No: 9384-62)

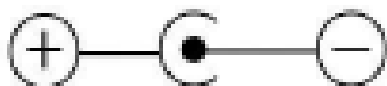

Fig: Polarity

Serial number

The serial number is located on machine plate (4) according to *Fig: Overview*.

Initial operation

LT2 is mechanically calibrated in the factory. The user may still want to check this. For the procedure, see section "Calibration".

Insert batteries in the display. If you use power adaptor, first connect the cable from the power adapter into the power connector (5) on the bike's right side, see *Fig: Overview*. Then plug the power adaptor into the wall outlet.

Perform the electrical calibration as specified in section "Calibration". Test by pedalling the bike. If the bike works properly, it is ready for use.

Monark Exercise AB recommends that you check the mechanical calibration once a year to ensure the cycle's accuracy.

Power on crank or flywheel

Monark bikes measure the effect of the flywheel, so it will be a friction of 6-8% if you measure the impact of the pedals (measure the effect of the crankshaft, the difference is 4-5 %). These percentages will be primarily due to friction in the chain, pedals and bearings.

LT2 is set to measure the workload at the flywheel. The bike can be set to work with effect in the pedals / crankshaft (the cycle constant).

Calories

There have been different theories on how to calculate this, since it depends on several factors and this means that it can only be seen as an estimate.

As a standard calculation, when we display calories on our calibrated bikes, we use: 1 minute with 100W gives 7 kcal. It is easy to convert watts to calories if it was on the flywheel, the formula is $1 \text{ W} = 0,2388 \times 10^{-3} \text{ kcal/s}$ with four decimals. But when you normally show calories you want to show the total amount of calories your body has used during your training, not only the calories "burnt" on the flywheel.

We have chosen the formula given above that we think complies with the results given for a standard cycle position.

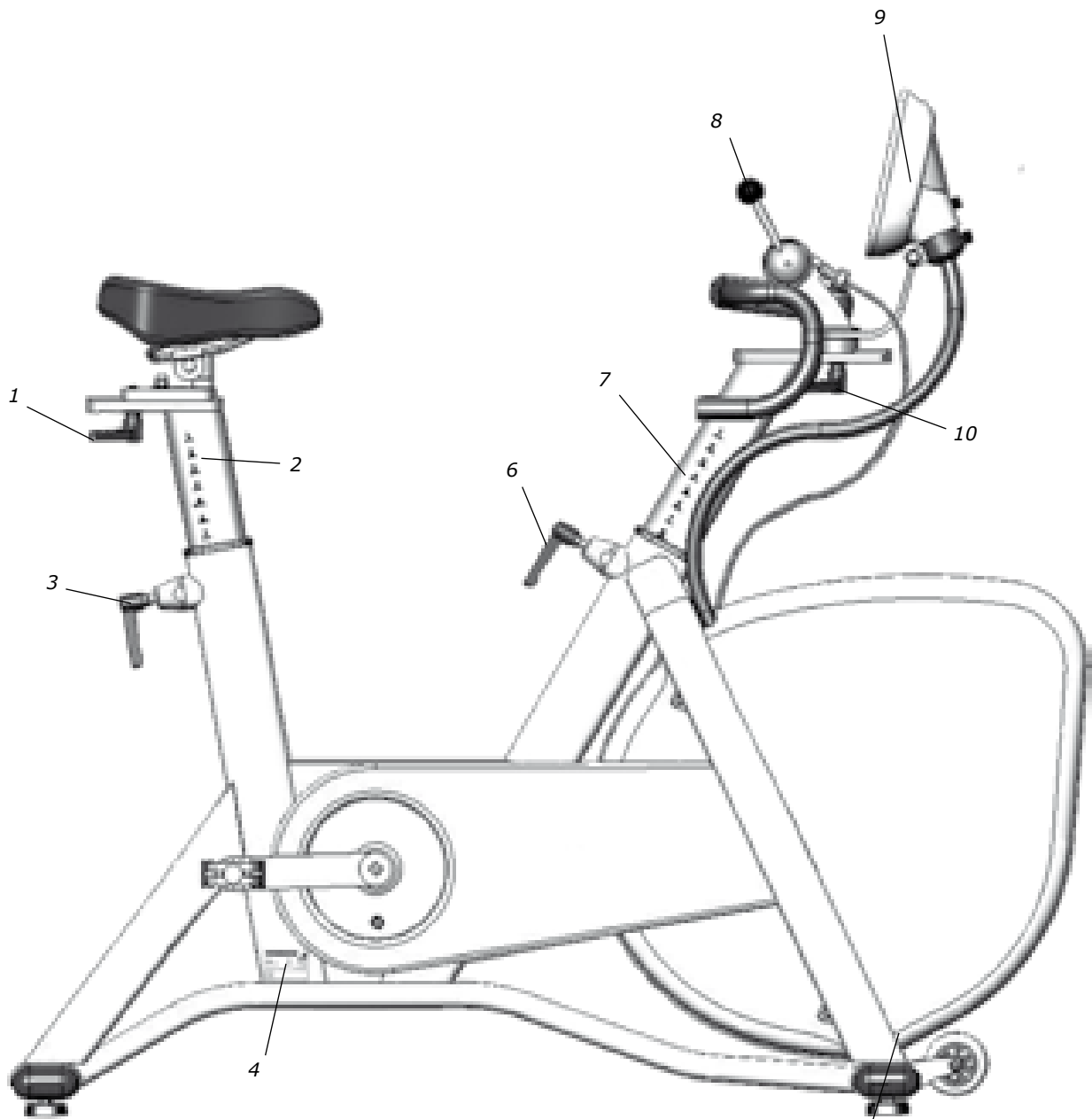

Fig: Overview

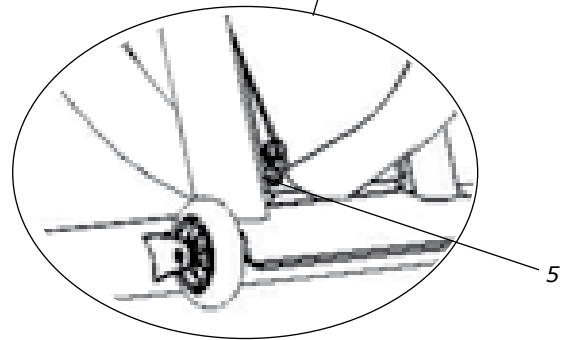

Fig: Overview

- 1) Knob for horizontal adjustment of saddle
- 2) Scale for height adjustment saddle
- 3) Locking handle for height adjustment saddle
- 4) Machine plate (serial number)
- 5) Power input
- 6) Knob for height adjustment of handlebar and display
- 7) Scale for height adjustment handlebar and display
- 8) Workload lever
- 9) Display
- 10) Knob for horizontal adjustment of handlebar and display

Bike adjustments

Adjustments of the bike

Crank	Steel, 52T, 172.5 mm standard, Q 146 mm
Pedals	9/16", combi SPD / Clips
Saddle	Moody
Seat post	Vertically: 530-940 mm Horizontally: 60 mm
Handlebar	Racing, Ø31,8 mm at clamp
Handlebar stem	Vertically: 500-910 mm Horizontally: 60 mm
Distance saddle - handlebar	170-815 mm

Bike adjustments

Seat height should be adjusted to a comfortable position. The appropriate height is when the knee is slightly bent when the sole of the foot is centred over the pedal axle with the pedal in the lowest position. When adjusting the saddle height and vertical position, loosen the respective locking handles. See *Fig: Saddle adjustment*.

The handlebar setting should be in a comfortable position when cycling. During longer exercise sessions it is recommended to occasionally change handlebar position. The handlebar can be adjusted both horizontally and vertically. This is done by loosening the respective locking handles. See *Fig: Handlebar adjustment*.

NOTE! Be sure that the stem and seat post are inserted to at least 100 mm in the frame. This is marked with "MAX" on the stem.

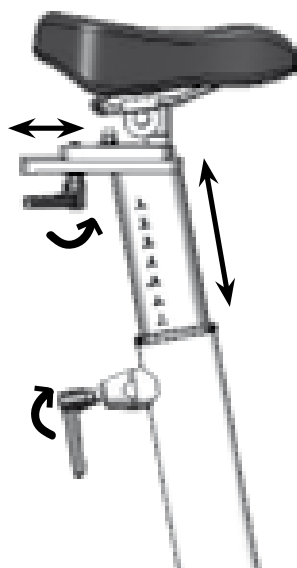

Fig: Saddle adjustment

Daily check

The following procedure ensures that the bike works for daily use.

- Check the HR function if you use chest belt, see section 'Heart rate'.
- Check the braking force by putting on a certain workload and check that the load is applied.
- Test by pedalling and check that a reasonable rpm is obtained - verify by a clock. Feel if the pedals move smoothly. Listen for unusual sounds. Adjust if necessary.
- Adjust the handlebar and saddle and make sure they are securely attached and that the adjustment is working properly.
- Make sure the support legs are in position by rocking the bike. Tighten if necessary.

If something unusual is found during the daily inspection that you cannot resolve, please call customer service.

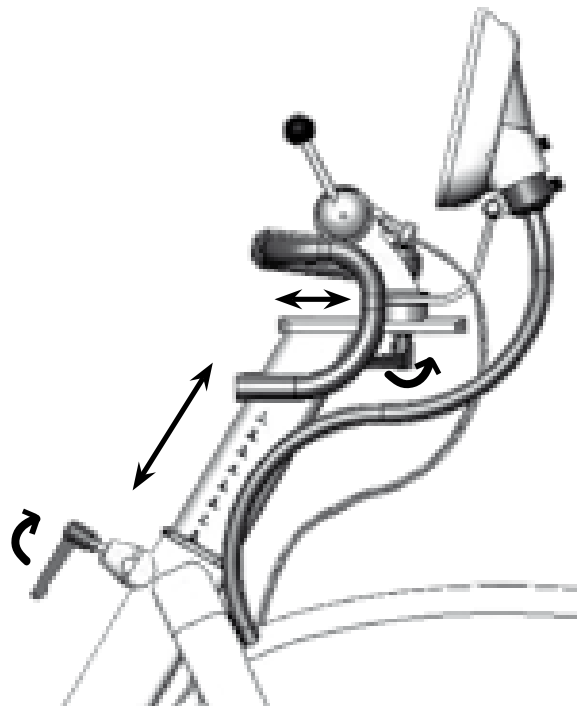

Fig: Handlebar adjustment

Pulse function

The user's heart rate can be measured with a chest belt that senses the electronic output of the heart. Chest belt ANT+ is not included but available as an accessory.

Heart rate monitoring requires that the chest belt is correctly placed. Make sure that your skin is clean where the chest belt should be placed. When it is correctly fitted the logo on the belt will be central and readable, outward and upright, by another person. The chest belt should be secured at a comfortable tension around the mid section, just below the breast muscle, see *Fig: Placement chest belt*. Moisten the electrodes before use, see *Fig: Electrodes on the back of the chest belt*.

NOTE! Electromagnetic waves can interfere with the telemetry system. Cellular phones are not allowed to be used near the bike during test.

Pulse standard (chest belts)

The following pulse standard / chest belts can be used:

- Standard, uncoded 5K chest belts (5-5.6 kHz)
- Chest belts with ANT+

Short range ANT+: 0.6-0.8 m

Long range ANT+: 4-5 m

Range 5K: 0.8 m (31 ½")

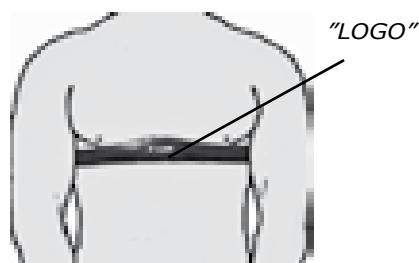

Fig: Placement chest belt

Pairing display and chest belt

Normally the display connects to the first ANT+ chest belt in "short range" and shows the heart rate until the chest belt is outside the "long range". If there is no ANT+ chest belt but a 5K chest belt in "short range", the heart rate from the 5K chest belt is displayed until the signal is lost.

ANT+ is prioritized and the first choice of the display. 5K is discriminated, but after 30 seconds with only 5K the display is locked to this chest belt as long as you do not lose the signal.

Monark Exercise AB recommend that you use an ANT+ chest belt for best function.

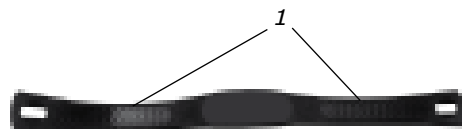

Fig: Electrodes on the back of the chest belt (1)

Display Description

Display	
Pedal revolution (RPM)	pedal revolutions / min
HR	bpm
TIME	min:sec
Workload (WATT alt. kpm/min)	Watt
Speed	km/h
Distance	km
Calories (KCAL)	kcal
% Max HR	%

Batteries: 4 x 1.5 V, R14
 Storing temperature: -10° C - +60° C
 Operating temperature: 0° C - +50° C

NOTE! Rechargeable batteries cannot be used!

The meter has the following functions:

- Settings for different units of measurement
- It is possible to calibrate the meter to get the correct workload
- Personal data such as age, max pulse, weight and gender can be set
- USB port for continuous output of data to an external computer
- The meter also shows current pulse as percentage of max. HR
- The workload is rpm independent

Sleep mode

Sleep mode is activated after 10 minutes if you do not press any button or if no rpm is recorded. This is to save battery power.

All settings are saved, but the personal settings are erased (to protect your personal privacy).

The meter wakes up when you press any button or if rpm is recorded. The meter goes directly to 'Quick start' (see separate section).

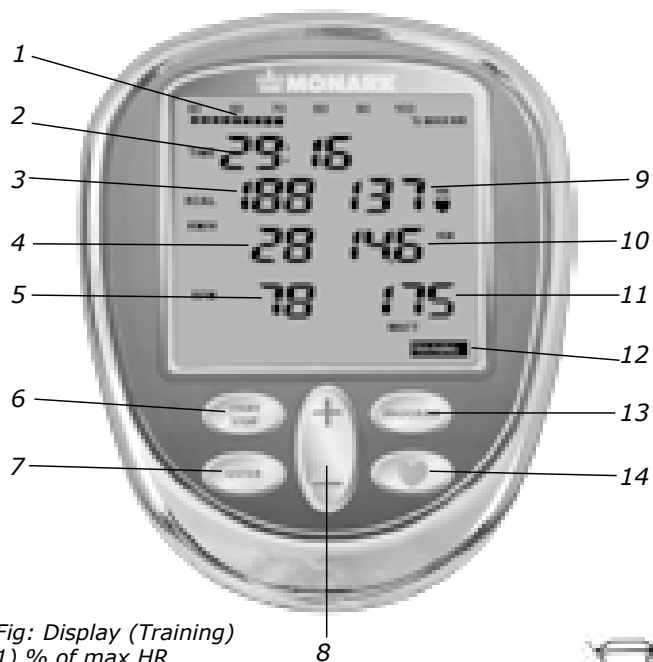

Fig: Display (Training)

- 1) % of max HR
- 2) Time
- 3) Kcal (estimated value)
- 4) Speed km/h
- 5) Pedal revolutions (rpm)
- 6) START STOP
- 7) ENTER
- 8) (+/-) button
- 9) Heart rate (HR)
- 10) Distance (km)
- 11) Workload (Watt)
- 12) Program
- 13) PROGRAM
- 14) HEART button



Workload adjustment

The workload is adjusted by using the control lever (1) located on the handlebars. From A which is a light workload to F which is a heavy workload.

Fine adjustment of the workload is done by the cable adjuster (2). See Fig: Workload adjustment.

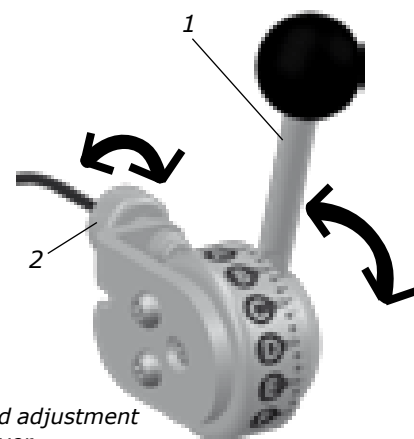

Fig: Workload adjustment

- 1) Control lever
- 2) Wire adjuster

Personal settings

Usually you are asked to set the personal data needed when you start a program or a test. This data can also be set before, during e.g. "Warm up" in Training program with this function.

Press **ENTER** to enter the menu for Personal settings.

Set weight
dAtA
Weight kg 75

Set gender
dAtA
Woman
Man

Set age
dAtA
Age 35

Set max HR
The meter suggests an estimated max HR based on your age (220-age) Change if desired.
dAtA
Max HR 185

The display returns to start view.

The settings are saved until the meter goes into sleep mode. When the display wakes up the personal settings are changed to default values (this is to protect your personal privacy).

Alternative power / force display

The meter displays power in watts (default). If you want to display the power in kpm / min instead, press the HEART button for 5 seconds. Then you can switch between WATT, KPM / MIN and current kp-value using the (+/-) button. Press ENTER or wait 10 seconds to confirm and exit the setting.

NOTE!

Even if you select kp as unit it is the power in watts as the value is calculated on.

The displayed kpm / min is a simplified calculation (1 kp = 10 N) according to Astrand's tables.

(Although the displayed kp value is correct and not rounded as above. For all calculations in the display the exact value is used, 1 kp = 9.80665 N)

Press **HEART** button for 5 seconds.

Set units
Default (kg, km, km/h, ml/min/kg)

Unit
KM/H KM
ML/MIN/ KG
KG

You can switch between these different power values.

Unit
KM/H KM
ML/MIN/ WATT
KG

When the loading value you want appears, press ENTER to confirm.

Unit
KM/H KM
ML/MIN/ KPM/MIN
KG

Unit
KM/H KM
ML/MIN/ KP
KG

The display returns to start view.

NOTE!
When you press the HEART button the meter starts searching for a HR signal.

User settings

Here you can make individual adjustments to optimize the bike for your needs on first use and when needed.

Press **ENTER** **and** **PROGRAM** for 5 seconds to set 'User settings'.

Set units
Unit
KM/H KM
ML/
MIN/ KG
KG

Set cycle constant
ConStAnt
1.00

Set metronome cadence
CAEnCE
60

Set cycle-ID
Id00

The display returns to start view.

If **START STOP** is pressed, or if no button is pressed for 20 seconds (in all steps), the changes are saved and the display returns to normal with the new settings active.

Units

Kg, km, km / h, ml / min / kg are default. You can switch between the different unit combinations with (+/-) button.

- Kg, km, km / h, ml / min / kg (default)
- Kg, km, km / h, METS
- Lbs, miles, miles / h, ml / min / kg
- Lbs, miles, miles / h, METS

Cycle constant

The cycle constant is as default set to 1.00. Change using the (+/-) button.

When the cycle constant is set to 1.00 the power is measured at the flywheel. This is used in Astrand test, YMCA etc.

When the cycle constant is set to 1.05 the power is measured at the crank. This is often used on electronically-braked bikes.

Metronome cadence

Metronome diodes show pedalling revolutions (rpm) relative to the set reference value. The metronome is located at the back of the meter. The default value is 60 and can be adjusted with (+/-) button. The green LED in the middle flashes twice for each pedal revolution which helps to keep the right pedal cadence, see *Fig: Display* and *Fig: Metronome*.

The meter can be rotated so that the rider does not see the values in the display, but only sees the flashing diodes (in order to keep the right pedal cadence).

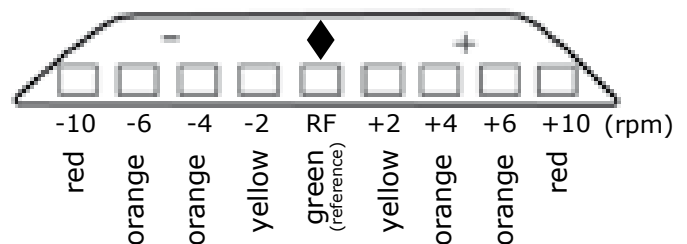

Fig: Metronome

BikeID

This ID is a parameter that the PC software can ask for. It is used to identify or number bikes when multiple bikes are controlled by same PC or similar.

Calibration

NOTE!

Calibration can only be done from the display!

To perform the calibration, you must have a 2 kg and a 4 kg calibration weight. These are available as accessories.

- Set the workload lever to minimum load
- Remove the cover over the flywheel
- Press the pressure roller and remove the wire from the black pulley (below the potentiometer) so that the pressure arm goes up completely and loosen the brake belt, see *Fig: Workload unit*.



Press **START STOP** and **PROGRAM** for 2 seconds to enter calibration mode.

Check the potentiometer value at 0 kp. It requires not be the same as shown in the picture, as it only shall be seen as an example.

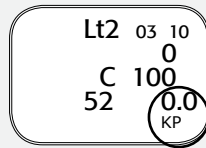

Hang a 2 kg calibration weight in the spring hook.

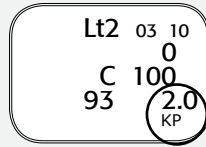

Hang a 4 kg calibration weight in the spring hook.

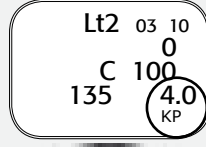

Hang a 6 kg (or 2 + 4 kg) calibration weight in the spring hook.

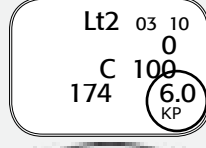

Two short beeps are heard and the calibration is finished.

Lift off the weights, reassemble the wire and put on the cover.

The bike is ready to use.



If you have started the calibration mode but change your mind, you can press the **START STOP** button to exit without saving. (However, if you press **ENTER** the calibration process has begun and must also be completed.)

Current potentiometer value

Current potentiometer value

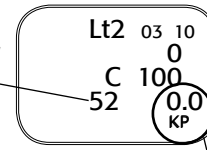

Next calibration point

For best flexibility we recommend a potentiometer value between 40 and 60 at 0 kp.

Error message:

CalErr - if the value is outside the window.

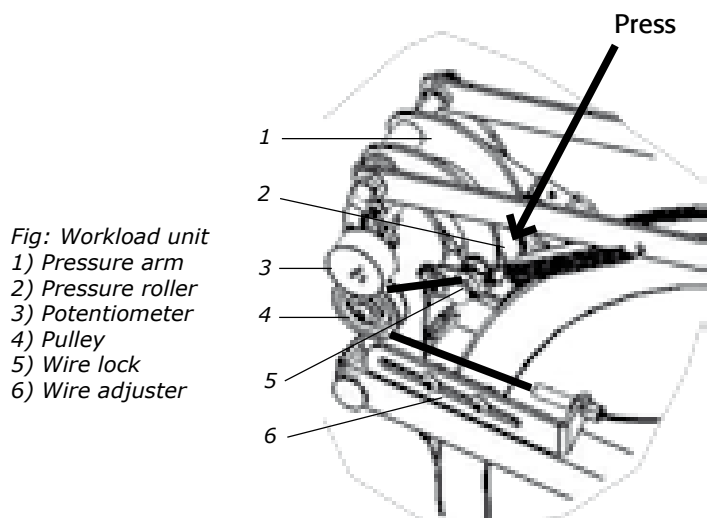

Fig: Workload unit
1) Pressure arm
2) Pressure roller
3) Potentiometer
4) Pulley
5) Wire lock
6) Wire adjuster

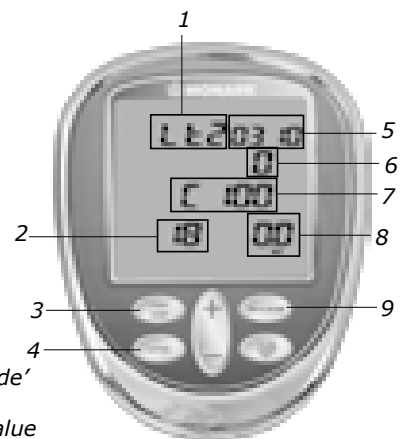

Fig: Display 'Calibration mode'
1) Bike model
2) Current potentiometer value
3) **START STOP** button
4) **ENTER** button
5) Software version
6) Hours of use
7) Cycle constant
8) Calibration point
9) **PROGRAM** button

Monark Exercise AB recommends that you check the mechanical calibration once a year to ensure the cycle's accuracy.

Training

PROGRAM
TRAINING

Personal data can be set for estimated HR (default HR is 185). See "Personal settings".

START STOP

TIME

KCAL	HR
KM/H	KM
RPM	WATT

Start Training program

START STOP

Stop Training program

To end the Training program, press START STOP and the results are displayed on three pages.

Average value

TIME **tot**

KCAL HR

KM/H KM

RPM WATT

Min value

TIME **Lo**

KCAL HR

KM/H KM

RPM WATT

Max value

TIME **HI**

KCAL HR

KM/H KM

RPM WATT

Interval training

You can do interval training by moving the workload control lever between two different modes, e.g. B and E.

ENTER

Press ENTER (for 5 seconds during the test) and a new test is started with the same settings.

START STOP

Press START STOP (for 5 seconds during the test) and the test is reset.



QUICK START

'Quick start' can be used as a separate program. (If START STOP is pressed, the TRAINING program is activated.)

The program is active and starts with base power, adjust with the control lever. No time is counted so the test person can warm up, use it as a 'quick start' or train without logging any values.

TRAINING

Press START STOP in 'Quick Start' and the display begins to show, count and log values. Press START STOP again and the test is completed and the results are displayed on three pages in the display and you can switch between the pages by pressing (+/-) button.

PROGRAM **METS**

START STOP

Set weight

dAtA
Weight kg 75

ENTER

Set age

dAtA
Age 35

ENTER

Set max HR
The meter suggests an estimated max HR based on your age (220-age) Change if desired.

dAtA
Max HR 185

ENTER

START STOP

Start METS program

TIME HR
METS L/MIN
RPM WATT

START STOP

Stop METS program

To end the test, press **START STOP** and the results are displayed on three pages.

Average value **Min value** **Max value**

TIME tot TIME Lo TIME Hi
METS HR METS METS METS
RPM L/MIN RPM L/MIN RPM L/MIN
WATT WATT WATT

ENTER Press **ENTER** (for 5 seconds during the test) and a new test is started with the same settings.

START STOP Press **START STOP** (for 5 seconds during the test) and the test is reset.



During the test METS and l/min are continuously counted and displayed.

Calculation

METS values are displayed and calculated from the current workload. The two VO_2 values displayed during the test continuously calculate the average value for 5 seconds.

The formula used (values from ASTRAND original table) to calculate VO_2 at different workloads is:
 $0.2333 \dots l / kpm = 0.01428 L / W$ (2.8 l / min at 1200 kpm)

This is according to Astrand's table between 150 W and 300 W, and a good approximation for 15-700 W and a cadence of about 50-65 rpm.

References / Literature:

- Astrand P-O, "Ergometri - konditionsprov", Monark, Sverige
- Åstrand I, "Aerobic work capacity in men and women with special reference to age", Acta Physiol Scand. 49 (suppl. 169), 1960
- Astrand P-O, "Experimental studies of physical working capacity in relation to sex and age", Munksgaard, Köpenhamn, 1952.
- Astrand P-O, Rodahl K, "Textbook of Work Physiology", McGraw-Hill, New York, 1970.

Troubleshooting guide

Symptoms	Probable Cause / Corrective Action
Display does not light up	<ul style="list-style-type: none"> No batteries in the meter No current in the outlet (if power adaptor is used). Check the fuses. Check cables and connections. Correct power adaptor? Check that the transformer information (voltage, current, polarity, AC / DC) in section "Facts" complies with the transformer which is used.
No workload	<ul style="list-style-type: none"> Check calibration. Check that brake belt is hooked in the spring.
No heart rate displayed	<ul style="list-style-type: none"> Check that the battery is alright in the chest belt, moisten your thumbs and click on the electrodes, a low clicking sound will be heard at the battery cover, alternatively that the heart rate is displayed in the computer software. Make sure the belt fits correctly on the test person, see Fig: Placement of chest belt in section "Heart Rate", and that the strap is sufficiently tightened. Moisten the electrodes, in severe cases it may be necessary to use gel alternative, one drop of dish washing liquid mixed in water. Pulse signal strength varies from person to person. Try the belt with a person known to have a good pulse wearing a chest belt. Make sure there are no loose cables. Use another HR receiver (HR watch or test bike monitor) to check the chest belt.
Irregular heart rate	<ul style="list-style-type: none"> Use an external unit, for example a HR watch, to check if it also indicates an irregular pulse. If this is the case, there is probably disturbance in the room. The disturbance may be electronic fields from power cables, elevators, lamps etc. or other electronic devices which are too close (e.g. cell phones). Move the bike to a different location in the room or change rooms. If an irregular HR remains it should be checked manually. If the HR remains irregular at work the person's health should be examined.
No rpm reading	<ul style="list-style-type: none"> Check cable.
Unable to calibrate force	<ul style="list-style-type: none"> The potentiometer shaft is not attached to the pendulum shaft, tighten the screw. The potentiometer is misadjusted.
There is a click noise when pedalling (increases with the weight)	<ul style="list-style-type: none"> The pedals are not tight. Tighten them or change pedals. The crank is loose. Check, tighten. The base bearing is loose. Contact your dealer for service.
Scratching sound is heard when pedalling	<ul style="list-style-type: none"> Check that the carriage block is taken off and that nothing is against the crank, chain, or wheel except the brake belt.
There's a click noise and a squeak noise when pedalling	<ul style="list-style-type: none"> Loosen the chain.

Service

Note that the text about service and maintenance is universal and that all parts may not be relevant to your bike.

Warning

Make sure the voltage indicated on the appliance corresponds to the local mains voltage before making connections.

Warranty

EU countries - Private use

If you are a consumer living in the EU you will have a minimum level of protection against defects in accordance with EC Directive 1999/44/EC. In short, the directive states that your Monark dealer will be liable for any defects, which existed at the time of delivery. In case of defects, you will be entitled to have the defect remedied within a reasonable time, free of charge, by repair or replacement.

EU countries - Professional use

Monark Exercise products and parts are guaranteed against defects in materials and workmanship for a period of one year from the initial date of purchase of the unit. In the event of a defect in material or workmanship during that period, Monark Exercise will repair or replace the product. Monark Exercise will not, however, refund costs for labour or shipping.

Other countries

Monark Exercise products and parts are guaranteed against defects in materials and workmanship for a period of one year from the initial date of purchase of the unit. In the event of a defect in material or workmanship during that period above, Monark Exercise will repair or replace (at its option) the product. Monark Exercise will not, however, refund costs for labour or shipping.

Service check and Maintenance

It is important to carry out a regular service on your ergometer, to ensure it is kept in good condition.

Always keep the bike clean and well lubricated.

Service action:

- We recommend isopropyl alcohol to disinfect the surface of the bike. Use a damp, but not wet cloth to clean the surface you wish to disinfect.
- Surface treatment with a rust inhibitor, especially when the bike is clean and the surfaces are dry. This is done to protect the chrome and zinc parts as well as the painted parts (4 times per year).
- Check now and then that both pedals are firmly tightened. If not the threading in the pedal arms will be damaged. When the ergometer is new it is important to tighten the pedals after 5 hours of pedalling (check this 4 times per year).
- Check that the pedal crank is secure to the crank axle (4 times per year).
- Be sure that the pedals are moving smoothly, and that the pedal axle is clear of dirt and fibres (4 times per year).
- When cleaning and lubricating be sure to check that all screws and nuts are properly tightened (twice a year).
- Check that the chain is snug and there is no play in the pedal crank (twice a year).
- Check that pedals, chain and freewheel sprocket are lubricated (twice a year).
- Be sure that the brake belt does not show significant signs of wear (twice a year).
- Check that the handlebars and seat adjustment screws are lubricated (2 times per year).
- Be sure that all moving parts, crank and flywheel are working normally and that no abnormal play or sound exists. Play in bearings causes fast wearing and with that follows a highly reduced lifetime.
- Check that the flywheel is placed in the center and with plane rotation.
- Grind the brake belt contact surface, see section "Brake belt contact surface" (once a year).

Batteries

If the display is battery-operated, the batteries are in a separate package at delivery. If the storing time has been long the battery power can be too low to make the computer act correctly. Batteries must then be changed.

Flywheel bearing

The flywheel bearing is long-term greased and requires no supplementary lubrication. If a problem arises, please contact your Monark dealer.

Crank bearing

The crank bearing is greased and normally requires no supplementary lubrication. If a problem arises, please contact your Monark dealer.

Transportation

During transport the brake cord should be tightened to prevent it from falling off the flywheel.

Replacement of brake belt

To replace the brake belt remove covers if necessary. Make sure that the belt is loose.

Pendulum bike with engine:

To loosen the brake belt on pendulum bikes with engine, connect power to the unit and raise the pendulum to 4 kp. Hold it there until brake belt is loose. Please note how the belt is assembled. Remove it from the bike. Attach the new brake belt and assemble the bike in reverse order.

Weight basket bike:

To loosen the brake cord on cycles with a weight basket set the basket to its upper position. Loosen the lock washer that is holding the cord and remove it from the tension center. Loosen or cut off the knot on the other end of the cord and then remove the whole cord from the bike. When assembling a new brake cord, first enter one end into the hole in the tension center, and tie a knot and let the knot fall into the bigger part of the hole. Lock the end of the cord with the lock washer.

Manual pendulum bike / exercise bike:

To loosen the brake belt on the bike remove all tension. Please note how the belt is assembled. Remove it from the bike. Attach the new brake belt and assemble the bike in reverse order.

NOTE!

When replacing the brake belt it is recommended to clean the brake surface. See "Brake belt contact surface".

Brake belt contact surface

Deposits of dirt on the brake belt and on the contact surface may cause the unit to operate unevenly and will also wear down the brake belt. The contact surface of the flywheel should be smoothed with fine sandpaper and any dust removed with a clean dry cloth.

Remove any potential covers and all workload on the brake belt and then remove it. Grind with a fine sand paper. Grinding is easier to perform if a second individual cautiously and carefully pedals the cycle.

Irregularities on the brake belt contact surface are removed by means of a fine sand paper or an abrasive cloth. Otherwise unnecessary wear on the brake belt may occur and the unit can become noisy.

Always keep the brake belt contact surface clean and dry. No lubricant should be used. We recommend replacing the brake belt when cleaning the contact surface. In regard to assembly and adjustment of the brake belt, see "Replacement of brake belt".

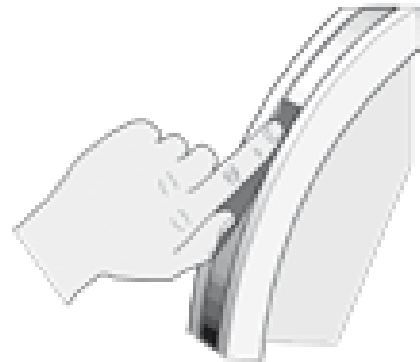

Fig: Brake belt contact surface

Chain 1/2" x 1/8"

Check the lubrication and tension of the chain at regular intervals. In the middle of its free length the chain should have a minimum play (3) of 10 mm (1/4 inch). See *Fig: Chain adjustments*. When the play in the chain is about 20 mm (3/4 inch) the chain must be tightened. Otherwise it will cause abnormal wear of the chain and sprockets. Therefore it is always recommended to keep the chain play as small as possible. Loosen the hub nut (2) on both sides and tense the chain with the chain adjuster (1) when needed.

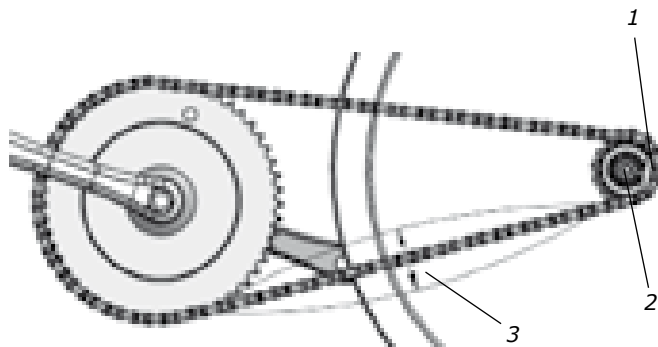

Fig: Chain adjustments
1) Chain adjuster
2) Axle nut
3) Chain play

When the chain has become so long that it can no longer be tightened with the chain adjusters it is worn out and should be replaced with a new one.

To adjust or replace the chain, remove covers if required.

To adjust the chain the hub nuts (2) should be loosened. Loosening or tightening the nuts on the chain adjusters (1) will then move the hub and axle forward or backward. Then tighten the nuts on the hub axle again. See *Fig: Chain adjustments*.

To replace the chain, loosen the chain adjusters as much as possible. Dismantle the chain lock (6) and remove the chain. Use pliers to both release the lock washer and mount it again (4). Put on a new chain and assemble the chain lock. The spring of the chain lock should be assembled with the closed end in the movement direction (5) of the chain. See *Fig: Chain replacement*.

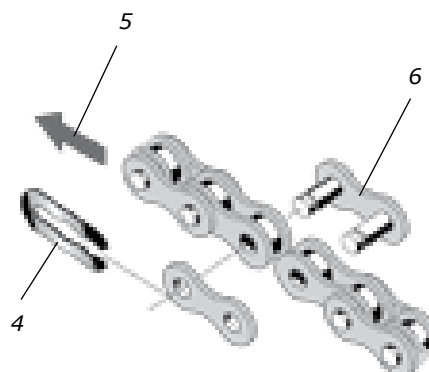

Fig: Chain replacement
4) Lock spring
5) Movement direction
6) Chain lock

NOTE!

At assembly the flywheel has to be parallel with the centerline of the frame. Otherwise the chain and sprockets make a lot of noise and wear out rapidly.

Then assemble the removed parts as above but in reverse order.

Freewheel sprocket

When replacing the freewheel sprocket remove frame covers if necessary. Remove the chain according to section "Chain 1/2" x 1/8".

Loosen the axle nuts and lift off the flywheel. Remove the axle nut, washer, chain adjuster and spacer on the freewheel side. Replace sprocket-adaptor and assemble the new parts in reverse order according to the above.

NOTE! Do not tighten the axle nut completely. It must be possible to loosen the adaptor-sprocket half a turn.

The sprocket should be lubricated with a few drops of oil once a year. Tilt the cycle to make it easier for the oil to reach the bearing. See *Fig: Lubrication*.



Fig: Hub assembly

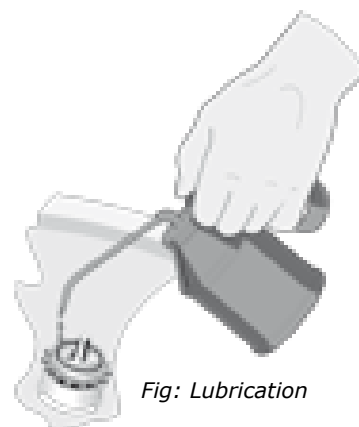
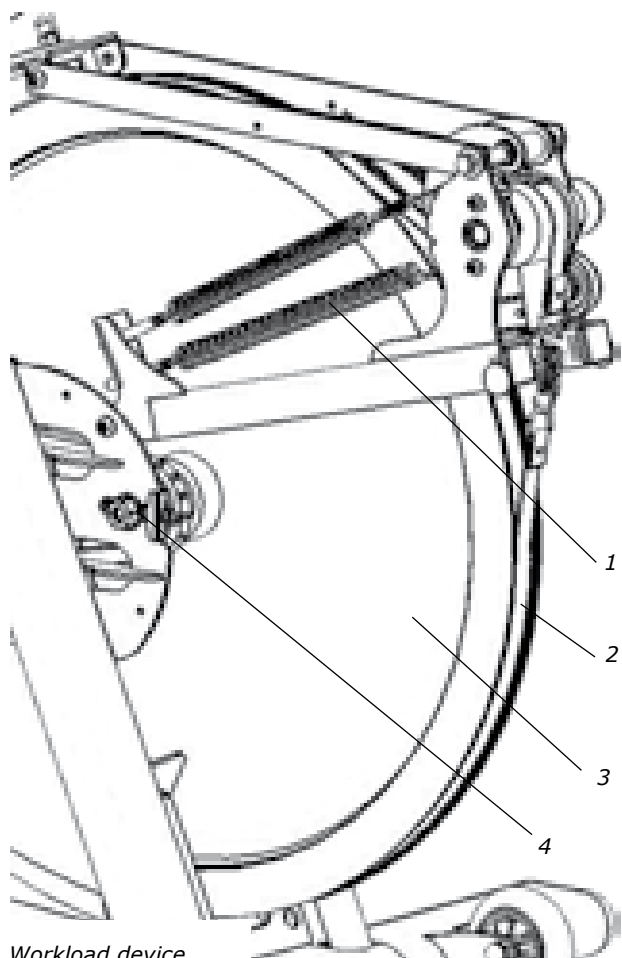
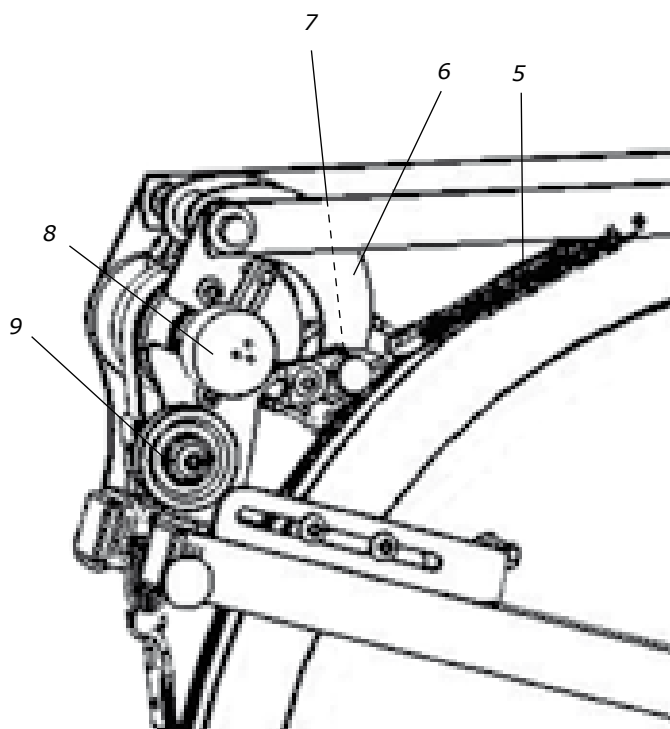

Fig: Lubrication

Spare parts list



Workload device
right side



Workload device
left side

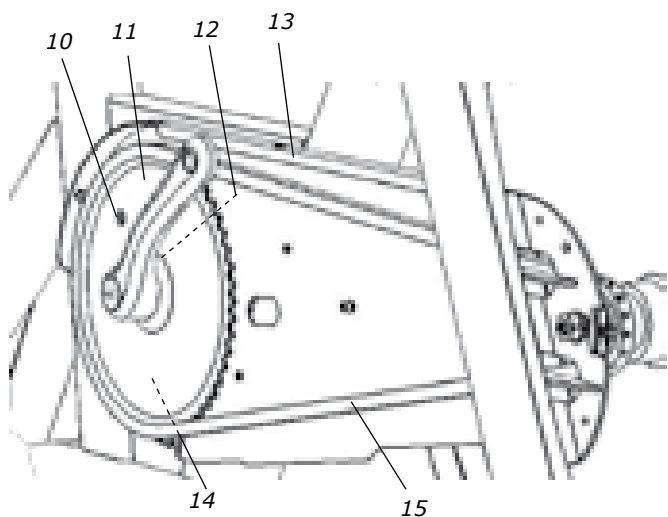

Pos.	Qty.	Art. No.	Description	Pos.	Qty.	Art. No.	Description
1	2	9125-86	Spring	9	1	9384-27	Pulley
2	1	9311-73	Brake belt LT, complete	10	1	9326-164	Magnet
3	1	9300-3	Flywheel, complete	11	1	9300-475	Crank set, 52T, 172,5 mm, Q 146 mm
4	1	9300-24	-Wheel suspension complete set	12	1	9300-480	Cartridge bottom bracket 68/110 mm
5	1	9100-20	Spring for press arm	13	1	9310-90	Inner chain guard
6	1	9311-59	Press arm	14	1	9311-161	Sensor with cable
7	1	9328-43	Tension lever	15	1	9310-118	Chain 9300, 120 L, with chain lock
8	1	9311-67	Potentiometer				

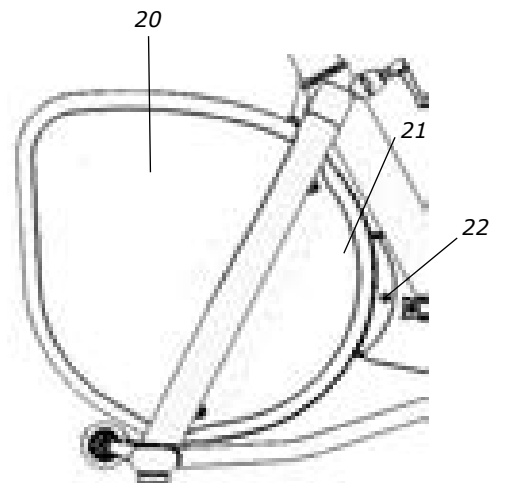
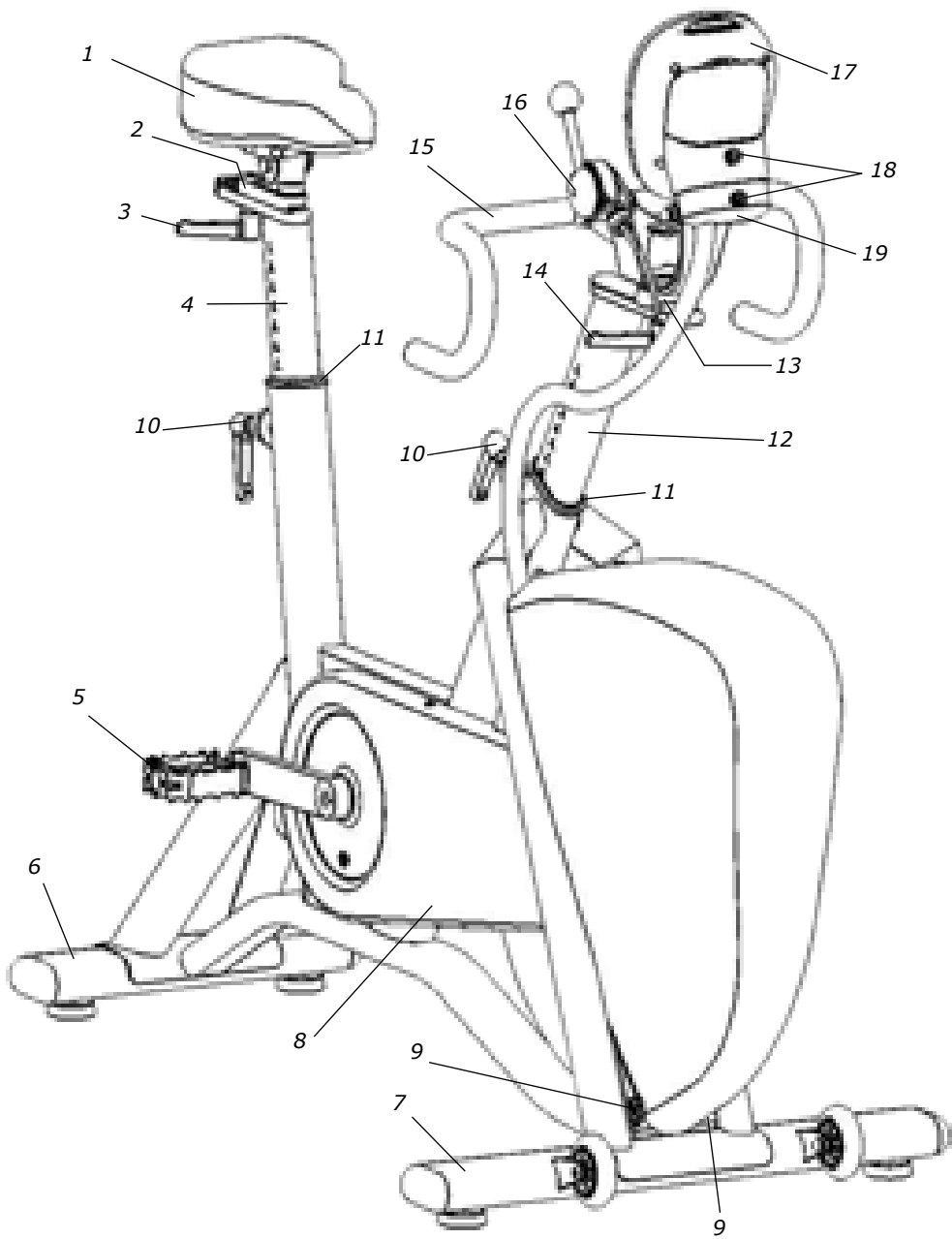

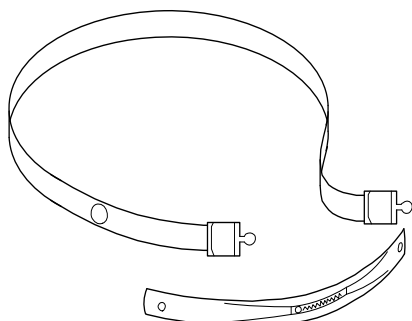

Fig: Chest belt with pulse transmitter (accessory)



Fig: Power adaptor SE (accessory)

Pos.	Qty.	Art. No.	Description	Pos.	Qty.	Art. No.	Description
1	1	9334-110	Saddle		1	9311-3	Handlebar with stem and clamp, complete
	1	9336-2	Saddle adaptor 22 mm	12	1	9311-33	-Handlebar stem
2	1	9311-23	Sledge, complete	13	1	9311-31	-Handlebar clamp
3	1	9311-24	-Locking handle M10x32, black	14	1	9311-24	-Locking handle M10x32, black
4	1	9311-21	Saddle post	15	1	C2305771-42	-Reparto corse handlebar
5	2	8321-75	Pedals SPD with clips and strap		1	C2600206	-Handlebar tape, black, CORK
6	1	9301-3	Support tube rear, complete	16	1	9311-4	Resistance control unit, complete
	2	9328-51	-Plastic cap		1	9311-44	-Wire adjustment
	2	9328-26	-Rubber foot with screw M8		1	9311-45	-Rubber ball 32/M8, black
7	1	9301-4	Support tube front, complete	17	1	9311-164	Display LT2
	2	9328-51	-Plastic cap	18	2	9000-104	Pole screw M5x12, black
	2	9328-26	-Rubber foot with screw M8	19	1	9326-801	End cap with hole, black
	2	9328-37	-Transport wheel, complete	20	1	9311-610	Cover
8	1	9310-595	Side cover rear, right	21	1	9310-605	Side cover rear, left
9	2	9000-103	Pole screw M5x12, white	22	1	9000-103	-Pole screw M5x12, white
10	2	9310-27	Piston locking, complete		1	9384-650	Power adaptor SE (accessory)
	2	9100-289	-Locking handle blue, M10x50		1	9384-62	Power adaptor other countries (accessory)
11	2	9328-315	Bushing with hole		1	9311-75	Chest belt (accessory)
					1	9000-211	Calibration weight 4 kg (accessory)
					1	9000-212	Calibration weight 2 kg (accessory)



Version 1402
Art. No: 7950-378

